

PerformArc® Robotic Welding Cells



PerformArc® 1100HW Robotic Welding Cell



Arc screen removed for clarity, optional tooling package shown.

Small Footprint, High Productivity and ROI

This high-production system has a footprint of 17 ft. x 10 ft. and allows for a second robot to be added, doubling throughput without requiring additional floor space.

Easy-to-slide teach access doors keep the system slim and allow for tight stacking.

The outboard Panasonic servo positioner allows the parts to be rotated into the desired welding position, maximizing torch access and welding quality.

Personal Safety

The 1100HW utilizes servo disconnect technology, removing drive power during fixture loading to prevent unexpected motion of the outboard axis and keeping employees safe.

ProStar™ Fume Collector Systems

Praxair provides turnkey, integrated filtration systems for all models including overhead capture

hood, ductwork package and ground based dust collector.

- Custom hoods fit all sizes and platforms
- Basic duct package includes spark arresstance
- Dust collectors for all metal types including SS with HEPA after filter capabilities
- Factory pre-wired controls
- Smoke detector with fan shutdown and fire suppression system.

Top View (Standard Single Robot)

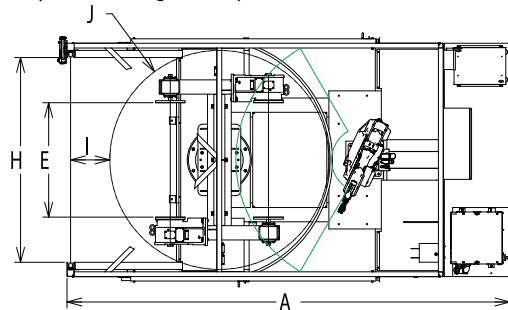

Side View (Optional Dual Robot)

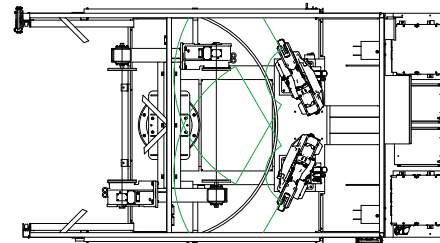

Front View

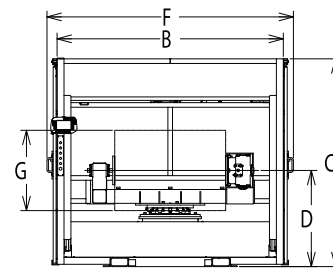

SPECIFICATIONS	PerformArc® 1100HW	
FRAME LENGTH	A	204 in.
FRAME WIDTH	B	114 in.
FRAME HEIGHT	C	90 in.
FIXTURE CL FROM FLOOR	D	42 in.
FIXTURE LENGTH	E	60 in.
CELL WIDTH	F	123 in.
FIXTURE ROTATION DIAMETER	G	40 in.
CELL FRONT OPENING MAX	H	102 in.
PENETRATION DISTANCE	I	18.5 in.
ROTATION DIAMETER	J	108 in.
SHIPPING WEIGHT		7600 lbs.

*Note: All dimensions are approximate.

STANDARD FEATURES

- 6 kg welding robot
- 64-bit controller with TFT color display teaching pendant utilizing Windows® CE
- Auto-Continuum™ Advanced MIG Welding System
- Auto-Continuum wire drive motor assembly
- Tregaskiss™ air-cooled welding torch
- Secondary rotation axis servo positioner 550 lbs. or 1100lb
- Miller designed and manufactured total productivity system

SYSTEM FEATURES

- Integrated operator interface (E-Stop, Auto Mode, Servo On, Mode Select, Table Load/Unload, Cycle Start, Collision Detect, Auto Backup)
- (2) Sliding doors for easy access to the teaching area
- TCP pointer and resident TCP check program
- Tip change monitor and maintenance program for easy torch upkeep
- Arc start retry, arc overlapping, flying arc start, password protection

POSITIONER GENERAL TECHNICAL SPECIFICATIONS

MAIN SWEEP AXIS

MODEL	Servo Positioner
MOTOR TYPE	3.5 kW AC Digital Servo
CONTROL TYPE	Servo Control
ROTATION TIME (180 DEG. INDEX)	t < 3.5 sec.
THROUGH HOLE (FOR UTILITY PASS THROUGH)	4.72 in.

SECONDARY AXIS (2)

MODEL	500 kg
MOTOR TYPE	1.6 kW AC Digital Servo
CONTROL TYPE	Servo Control
PAYLOAD (PER SIDE)	1,100 lbs.
PAYLOAD OFFSET (FROM POSITIONER CL)	Please consult manual
THROUGH HOLE (FOR UTILITY PASS THROUGH)	2.16 in.

Power Source Options

Advanced MIG (GMAW)	TIG (GTAW)
Auto-Continuum™ 350A / 500A	Dynasty® 400A
TAWERS 350A / 450A	Dynasty® 800A
	BP4-300A

Robot Options

1100HW	
Single	Dual Robot
TM1400	TM1400
TM1600	TM1600
TM1800	