



Operating Manual

LINDE ProSpec™

Regulator

High-Pressure Gas Cylinder Applications

General Information/Publications Support:

Linde
Technical Communications
P.O. Box 44
Tonawanda, NY 14151-0044
USA
www.Linde.com
info@Linde.com

Phone: 800-Linde
800-772-9247
716-879-2155
Fax: 800-772-9985
716-879-2146

Linde Inc.

Web: www.LindeDirect.com

Email: SpecialtyGases@Linde.com

Technical/Customer Support

Call 1-877-Linde (1-877-772-9247),
and follow the voice prompts.

In an emergency, call 1-800-Linde (1-800-772-9247).

Notices

Business Confidential: This manual contains confidential and proprietary information of Linde and is provided in confidence a solely for use in conjunction with the *ProSpec™* Regulator. The manual may not be reproduced or its contents disclosed to third parties without the prior written consent of Linde.

Disclaimers: All information referred to and/or included in this manual is current as of the issue/revision date of this manual. Linde, Inc. makes no warranty or representation with respect to the accuracy of the information or with respect to the suitability of the use of such information outside Linde plc., nor does Linde plc assume responsibility for any injury or damage which may result, directly or indirectly, from the use of such information.

This manual could include technical inaccuracies or typographical errors. Changes are made periodically to the information herein; these changes will be incorporated in subsequent revisions of the manual. Linde reserves the right to make improvements and/or changes to the product(s) and/or programs described in this manual at any time and without notice.

Installation Disclaimer: Installation of the *ProSpec™* Regulator, controls, and associated piping is the responsibility of the customer unless Linde has contracted to do a turnkey installation.

The installation information in this manual is offered for use by technically qualified personnel at their discretion and risk. All statements, technical information, and recommendations are based on tests and data that Linde believes to be reliable, but the accuracy or completeness is not guaranteed, and no warranty of any kind is made with respect to this information.

Linde provides assistance in commissioning the system and may also provide technical assistance for system installation and testing to determine operating conditions.

Trademarks: *Linde*, *Making our world more productive*, *ProSpec*, and the *Flowing Airstream* design are trademarks or registered trademarks of Linde Technology, Inc. in the United States and/or other countries. Other trademarks used herein are trademarks or registered trademarks of their respective owners.

BLANK PAGE BY DESIGN

Read These Instructions

Danger, Warning, Caution, and Note Statements

Dangers, Warnings, Cautions, and Notes appear throughout this manual. A sample of each statement appears below. Within each sample, a definition of the statement type and its purpose is given.



DANGER: DANGERS alert you to an immediate hazard that causes serious injury or death and requires special precautions to be taken.



WARNING: WARNINGS alert you to a potential hazard that causes serious injury or death *under certain conditions*.



CAUTION: CAUTIONS alert you to a non-immediate or potential hazard or an unsafe practice that presents a minor threat of personal injury or damage to equipment, data, or processes.



NOTES emphasize or remind you of an important piece of information.

BLANK PAGE BY DESIGN

Table of Contents

Notices.....	iii
Read These Instructions.....	v
Chapter 1 – Safety	
1.1 Safety Practices for Regulators.....	1-1
1.1.1 User Responsibility.....	1-3
1.2 Basic Safety Recommendations.....	1-4
1.3 Basic Hazards.....	1-5
1.3.1 Asphyxiation.....	1-5
1.3.2 Pressure.....	1-6
1.3.3 Gas Processing Equipment and Fires.....	1-6
1.3.4 Flammability.....	1-7
1.3.5 Toxicity.....	1-7
1.3.6 Poisons.....	1-7
1.3.7 Corrosion.....	1-7
1.3.8 Oxidizers.....	1-7
1.3.9 Reactivity.....	1-8
1.4 Cleaning.....	1-8
1.4.1 Cleaning for Oxygen Service.....	1-8
1.4.2 Cleaning Precautions.....	1-9
1.5 References.....	1-9
Chapter 2 – Equipment Description	
Chapter 3 – Installation	
3.1 Gas Cylinder Setup.....	3-2
3.2 Regulator Connection.....	3-2
3.2.1 Regulator Parts.....	3-3
Chapter 4 – Operation	
4.1 Temporary Shutdown.....	4-3
4.2 Extended Shutdown.....	4-3
4.2.1 Normally Open Systems or Complete System Disassembly.....	4-3
4.2.2 Isolated Gas Systems.....	4-4
4.3 Isolated System Cylinder Change.....	4-4

Table of Contents

Chapter 5 – Maintenance and Repair

Chapter 6 – Troubleshooting

Index.....I-1

List of Figures

2-1 Linde® ProSpec™ Regulator.....2-2

3-1 Teflon Tape Application.....3-3

List of Tables

1-1 Summary of Reference Publications.....1-11

6-1 Troubleshooting.....6-2

1. Safety



WARNING: Do NOT operate this equipment until you read and understand the operating, maintenance, and safety instructions included in this manual and in the supplier manuals. Only trained and responsible personnel should work with or around this equipment. Wear appropriate personal protective equipment (PPE), and turn off the power and lock out the equipment before performing any installation, maintenance, repair, or troubleshooting procedures, per applicable requirements.



WARNING: To avoid serious injury, pay attention to all precautionary labels attached to equipment, cylinders, containers, and boxes prior to startup. Do not remove or obscure any label. If a label is missing, becomes worn, or is difficult to read, replace it with a new one. Labels are available from your Linde representative.



This chapter contains information to promote safety in the operation and maintenance of this equipment. It is not intended to supersede, replicate, or replace any safety documentation or procedures provided from or established by official safety sources.

Read and understand the Safety Data Sheets (SDSs) for the materials used with this equipment. All personnel who work in the vicinity of this equipment should read, understand, and follow all safety information contained in the SDSs and all applicable government and facility safety regulations.

1.1 SAFETY PRACTICES FOR REGULATORS

- Pressure test and leak test all systems before system startup. Purge the system with inert gas.
- Consult the cylinder distributor for the proper use of cylinders and for any restrictions on their use (for example, flow rate and temperature requirements).
- Store cylinders with valve caps screwed on. Secure the cylinders to a wall or column. Handle cylinders carefully with valve caps screwed on. The cap reduces the potential that the cylinder valve will break off if the cylinder is accidentally dropped or falls over. The cap also protects the cylinder valve from damage to screw threads, which could cause leaky connections.
- Ensure that all manifolds used with flammable gases have flashback arrestors to stop any burning gas in the pipeline from returning back to the manifold or cylinders.

1.1 SAFETY PRACTICES FOR REGULATORS (Con't)

- No smoking is permitted near oxygen, nitrous oxide, any other oxidizer, flammable gases, or flammable mixtures, or in areas where cylinders are stored.
- The manifold and cylinders must be kept clean where oxygen or nitrous oxide is used. Prevent oil, grease, or combustible substances from contact with oxygen or nitrous oxide storage or handling equipment. When these materials contact oxygen or nitrous oxide, they are readily ignitable and intensely burn after ignition.
- Never use an open flame when leak testing.
- Open valves slowly when high-pressure gases are being used.
- Ensure that a cylinder contains the correct gas before connecting it to any regulator, manifold, or compressed gas apparatus.
- Leak-test any regulator or distribution pipeline before use.
- Ensure that the gas in a pipeline is the correct gas for the intended use.
- Close all cylinder valves before disconnecting cylinders from a regulator or manifold.
- Remove all empty cylinders from the area before connecting full cylinders.
- Test cylinders to ensure that the cylinders are full before connecting to a manifold.



WARNING: Maximum allowable working pressure (MAWP) indicated on product labeling is for the regulator only. Ratings for peripherals/accessories may be less than the pressure indicated on the product label. Do not exceed the pressure ratings of the attached peripherals/accessories and the MAWP for the regulator. Contact your gas supplier for more information.



WARNING: Select the appropriate tubing for regulators with tube fittings. Use seamless tubing with the proper consideration given to wall thickness and material. Contact your gas supplier for more information.



WARNING: Install an appropriately sized relief device downstream of the regulator in the system to prevent damage to equipment and/or injury to personnel if an internal failure of the regulator occurs.



WARNING: Do not attempt to weld, braze, or tighten fittings while the regulator or piping system is pressurized. Do not weld or braze components with soft internal seal materials, valves, check valves, or regulators



All gas distribution piping systems must meet the appropriate industrial standards for the intended service and must be thoroughly cleaned before use. Some applicable safety rules and precautions for the United States are listed in Table 1-1 at the end of this chapter.

1.1.1 User Responsibility

This equipment will perform in conformity with the description contained in this manual and accompanying labels and/or inserts when installed, operated, maintained, and repaired in accordance with the instructions provided. This equipment must be periodically checked for leaks and functionality. Do not use equipment that is not properly working.

Immediately replace parts that are broken, missing, worn, or distorted. Linde recommends that a telephone or written request for service advice be made to the Linde North American Technical Support Center, **PHONE: 1-877-Linde (1-877-772-9247)**.

Do not alter any equipment or any of its parts without prior written approval by Linde. The user of this equipment is solely responsible for any malfunction that results from improper use, faulty maintenance, damage, improper repair, or alteration by anyone other than Linde or a service facility designated by Linde.

1.2 Basic Safety Recommendations

- **Prevent formation of unsafe atmospheres**—Safe operation requires that properly engineered ventilation and atmospheric monitoring systems are installed and operating properly. Creating a confined space presents the potential for unsafe atmospheres. If dangerous levels of a gas are detected, evacuate the effected area immediately. Do not re-enter the area until safe conditions are restored.
- **Ventilate working areas**—Prevent any leaking gases from accumulating. Vent all gases to the outside to an area that is safely away from people and away from any possible ignition source. Before restarting the equipment, ensure that all parts affected by repairs have been restored to their proper operating condition and that the lines have no leaks.
- **Prevent injury**—Wear safety glasses and other appropriate PPE when the Safety Data Sheets (SDSs), task, or code dictates. Ensure that all tools and instruments used are in good condition. Be aware that high-velocity gas may be released at vents and safety relief valves.
- **Maintain safety devices**—Check all safety devices at least annually or as otherwise required by local codes or manufacturer recommendations. Properly maintain safety valves.



WARNING: Never bypass safety devices, and never operate the equipment outside its specified limits.

- **Prevent fires or explosions**—Eliminate all possible ignition sources when making repairs. Do not permit open flames; sources of ignition; or the carrying or use of matches, lighters, or tobacco products in the vicinity of equipment containing flammable gases. Store flammable chemicals in accordance with the Safety Data Sheet's (SDS's) instructions. Ensure proper grounding of equipment. Use only spark-proof tools and explosion-proof equipment when working around flammable materials.
- **Ensure safe maintenance and repair**—Only qualified personnel should repair the equipment. Protect personnel from hazards related to unexpected energizing, startup, or release of stored energy during servicing or maintenance by using strict equipment lockout/tagout procedures.



DANGER: Failure to properly isolate equipment, electrical systems, and piping can cause asphyxiation, fire, and/or explosion. Positively isolate the equipment from the gas supply and the process material before performing repair work. It is not sufficient to simply close valves. Lines and tubing must be blanked or disconnected.

1.3 Basic Hazards



DANGER: Additional hazards may be associated with the gases used in your application and with your equipment. Determine which hazards you may encounter, and be prepared to handle them. Refer to the Safety Data Sheets (SDSs) supplied with the gases and all applicable government regulations and industry safety standards.

1.3.1 Asphyxiation



DANGER: Exposure to gases or vapors may cause asphyxiation. Proceed with caution and in accordance with the Safety Data Sheet (SDS).

Practically all gases can act as simple asphyxiants by displacing the natural oxygen in the air. To prevent serious personnel injury and possible death, provide adequate ventilation to the outside environment in areas where any process gas may accumulate. Consider the increased potential for asphyxiation when pressure testing or purging equipment with nitrogen or other non-air gases.

1.3.2 Pressure



DANGER: Mishandling of pressurized process equipment or gas cylinders can result in death, serious injury, or property damage. Handle pressurized equipment and cylinders with extreme care and in accordance with the manufacturer's instructions.

The contents of this equipment are under pressure. Sudden or uncontrolled release of pressurized gas can cause serious injury. The gases themselves or objects propelled by the gases may strike personnel at high speed or possibly cause a spark-induced fire. Avoid high-pressure hazards through careful inspection and proper handling of equipment and cylinders. The pressure-relief devices (for example, safety valves, bursting discs) supplied with this equipment for over-pressure protection must be maintained at regular intervals to ensure their proper operation.

Be aware of the locations at which high-pressure gases exist and the precautions for operating or maintaining equipment that handles these gases.

1.3.3 Gas Processing Equipment and Fires



DANGER: Fires in or near gas processing equipment can result in the release of process gases. Depending on the gases released, responding personnel may be at risk for asphyxiation, toxicity, flammability, and/or explosion hazards. Emergency response planning must consider the presence and potential impact of process gases.

Adequate ventilation of enclosed areas serves as the chief precaution against an accumulation of the flammable gases together with safe procedures and equipment to detect possible leaks. Identify potential sources of ignition. Ensure that electrical equipment is designed for the presence of flammable gases per the National Electrical Code (NEC).

1.3.4 Flammability



DANGER: Flammable gases can form explosive mixtures with air. If allowed to concentrate in a work area, even a gas with a relatively low flammability can explode. Provide adequate ventilation.

This equipment contains flammable gases. Guard against the possibility of fire or explosion. Refer to the Safety Data Sheet (SDS) for the gas(es) used in your application to find out their flammability ranges.

Adequate ventilation of enclosed areas serves as the chief precaution against an accumulation of the flammable gases together with safe procedures and equipment to detect possible leaks. Identify potential sources of ignition. Ensure that electrical equipment is designed for the presence of flammable gases per the National Electrical Code (NEC).

1.3.5 Toxicity



DANGER: Toxic gases can cause personnel injury or death through breathing, absorption through the skin, or swallowing. Hydrogen chloride and other anhydrous toxic gases will react with moisture in the eyes. Provide adequate ventilation and appropriate personal protective equipment (PPE).

This equipment contains toxic gases. Adequate ventilation of enclosed areas serves as the chief precaution against an accumulation of toxic gases. In addition, for highly toxic gases, install automatic devices to constantly monitor gas concentrations and set off alarms if the concentrations approach a danger point.

Precautions against skin or eye contact with toxic gases include a thorough knowledge of the dangers, training for all personnel handling such gases, the development of procedures and equipment for handling them, and the use of special protective clothing and equipment (such as self-contained breathing apparatus (SCBA), portable gas monitors, protective garments, gloves, and face shields).

1.3.6 Poisons



DANGER: Poisonous gases can be fatal if inhaled, even in very small quantities. Provide adequate ventilation and appropriate personal protective equipment (PPE).

This equipment contains poisonous gases. The exposure controls and limits, including the Threshold Limit Values (TLVs) for the specialty gases used with this equipment, are stated on the cylinder body labels and the Safety Data Sheet (SDS) for each gas.

Use these gases only in well-ventilated areas. Precautions against skin or eye contact with poisonous gases include a thorough knowledge of the dangers, training for all personnel handling such gases, the development of procedures and equipment for handling them, and the use of special protective clothing and equipment (such as self-contained breathing apparatus (SCBA), portable gas monitors, protective garments, gloves, and face shields).

1.3.7 Corrosion



DANGER: Corrosive gases can attack and irreversibly damage human tissue and other substances such as metal. Avoid contact with corrosive gases.

This equipment contains corrosive gases. Precautions against skin or eye contact with corrosive gases include a thorough knowledge of the dangers, training for all personnel handling such gases, the development of procedures and equipment for handling them, and the use of special protective clothing and equipment (such as self-contained breathing apparatus [SCBA], portable gas monitors, protective garments, gloves, and face shields). Also, safety showers and eyewash fountains should be immediately accessible.

1.3.8 Oxidizers



DANGER: Oxidizing gases vigorously accelerate combustion and create a fire hazard without being flammable themselves. Contact with flammable materials may cause fire or explosion. Provide adequate ventilation.

This equipment contains oxidizers. Avoid contact with oils, greases, and other flammable materials. Provide adequate ventilation.

1.3.9 Reactivity



DANGER: Some of these gases are reactive and may explode if mixed with other chemicals. Reverse flow into the cylinder may cause it to rupture.

Always follow these instructions and your facility's standard operating procedure (SOP) when connecting the cylinder to equipment or using the gas to avoid reaction and reverse flow. Refer to the Safety Data Sheet (SDS) for the gas(es) used in your application to determine reactivity, if any.

1.4 Cleaning

1.4.1 Cleaning for Oxygen Service



WARNING: Any equipment to be used for oxygen service must be thoroughly cleaned. Contamination can lead to sudden combustion of equipment components, including metals with significant release of energy and molten materials, and the potential for injury of personnel.

Many metallic and non-metallic materials that normally do not burn in air can burn readily in high concentrations of oxygen. Contamination in oxygen equipment can be easily ignited, which can promote the combustion of equipment materials of construction. Particles picked up and carried by oxygen flows can impact the inside of equipment. The energy of this impact can also ignite equipment materials. System cleanliness and materials selection are, therefore, extremely critical to safe oxygen system operation.

Use only Linde-approved replacement parts. Ensure that all replacement parts are compatible with oxygen and cleaned for oxygen service. Keep repair parts in clean, sealed plastic bags until ready for use. Use tools that have been cleaned for oxygen service. Take extra precautions not to introduce contamination into oxygen equipment during maintenance activities.

All areas where oxygen and oxygen equipment are used, handled, or stored must be kept clean to prevent ignition. Because even normal industrial dirt and soot can support combustion, the exterior surfaces of all equipment used in oxygen service must be kept clean.

Refer to *Cleaning for Oxygen Service*, CGA publication G-4.1, for approved methods of cleaning for oxygen service and for information on oxygen-compatible materials.

Where components of equipment cleaned for oxygen service must be replaced, use appropriate cleaning standards to ensure that equipment has been safely prepared for the application for which it is intended. Do not use cleaning agents that leave organic deposits on the cleaned surfaces. Always handle equipment that will come in contact with oxygen with clean gloves or with hands that have been washed clean of oil. Carefully inspect all cleaned parts. If any evidence of contamination is noted, clean the part again.

1.4.2 Cleaning Precautions



WARNING: Some cleaning agents or solvents can emit toxic fumes. Conduct all cleaning operations in a well-ventilated area. Even though many cleaning agents are not highly toxic, take appropriate precautions.

All new equipment, as well as used equipment that may have become contaminated during service, must be thoroughly cleaned. Any residue could contaminate the process gas and may constitute a safety hazard.

Perform cleaning in accordance with applicable cleaning standards to ensure that the equipment has been safely prepared for the application for which it is to be used. Carefully inspect all cleaned parts. If any evidence of contamination is noted, clean the part again.

1.5 References

Table 1-1 is a summary of applicable reference publications for the United States. Go to the Linde Direct Specialty Gas Information Center at www.LindeDirect.com for helpful technical and safety information.

Table 1-1
Summary of Reference Publications

Publication Number	Title	Source
P-3499	Safety Precautions and Emergency Response Planning Awareness	Call 800-44LINDE.
	Safety Data Sheet (SDS) for each specific gas used.	Obtain from your gas supplier. If Linde is your gas supplier, call 800-Linde or see www.Linde.com .
G-4.1	Cleaning Equipment for Oxygen Service	
G-4.4	Industrial Practices for Gaseous Oxygen Transmission and Distribution Piping Systems	
P-1	Safe Handling of Compressed Gases in Containers	
P-9	Inert Gases—Argon, Nitrogen, and Helium	
P-39	Oxygen-Rich Atmospheres	
SB-2	Oxygen-Deficient Atmospheres	Compressed Gas Association (CGA) www.cganet.com
SB-15	Avoiding Hazards in Confined Work Spaces During Maintenance, Construction, and Similar Activities	
TB-9	Guidelines for the Proper Handling and Use of the CGA 630/710 Series Ultra High Integrity Service Connections	
AV-7	Characteristics and Safe Handling of Carbon Dioxide	
NFPA-70	National Electrical Code (NEC)	National Fire Protection Association (NFPA) www.nfpa.org
29 CFR Section 1910	OSHA Regulations	
1910.146	Permit-Required Confined Spaces	Superintendent of Documents Government Printing Office www.osha.gov
1910.147	The Control of Hazardous Energy (lockout/tagout)	

Table 1-1
Summary of Reference Publications

Publication Number	Title	Source
	Threshold Limit Values (TLVs) for Chemical Substances and Physical Agents	American Conference of Governmental Industrial Hygienists (ACGIH) Technical Affairs Office www.acgih.org
Z49.1	Safety in Welding and Cutting	
Z244.1-1982	American National Standard for Personnel Protection—Lockout/Tagout of Energy Sources—Minimum Safety Requirements	American National Standards Institute, Inc. www.ansi.org
NFPA 1	Uniform Fire Code	
51	Oxygen-Fuel Gas systems for Welding and Cutting	National Fire Protection Association www.nfpa.org
51B	Cutting and Welding Processes	
12812-0000	Personal Protection Lockout/Tagout of Energy Sources	National Fire Protection Association www.nfpa.org
15242-0000	Lockout/Tagout booklet	

2. Equipment Description



“ProSpec™” is the new brand-name for the “ProStar® Platinum” series of products from Linde® Specialty Gases & Equipment. ProSpec regulators are designed for high-pressure gas cylinder applications.



For additional details, ordering information, operation, and safety guidelines, go to www.LindeDirect.com or call 1-877-772-9247.

The Linde® ProSpec™ Regulator (Figure 2-1) is used for high-pressure gas cylinder applications.



Figure 2-1: Linde® ProSpec™ Regulator PRS3012-3331-580 shown

2. Equipment Description (Con't)

Know the properties and special handling requirements of the gas being used. Many gases are dangerous. Gases can be flammable, toxic, corrosive, simple asphyxiant, or oxidizers. Equipment failure or misuse can lead to problems. Problems could involve gas release through a relief valve or a regulator diaphragm. Establish proper safety measures to handle these and other component failures.

- Ensure that the assembly purchased is suitable for the gas and type of service intended. The system label provides the model number, serial number, and maximum inlet pressure.
- Ensure that the equipment received conforms to the order specifications. The user is responsible for selecting equipment compatible with the conditions of pressure, temperature, flow, etc. Selection information can be found in Linde technical data sheets and Linde representatives are trained to aid in the selection process.
- Inspect the assembly upon receipt to verify that there is no damage or contamination. Pay particular attention to connecting threads. Linde assembles system components to exacting leak-tight standards. However, the customer should inspect for loosening of parts that may occur in shipping or installation.
- Loose parts can be dangerously propelled from an assembly. If there are adverse signs (leakage or other malfunction), return the assembly to the supplier.
- Return soiled regulators for cleaning. In some cases, a simple external dust or grease can be removed by a clean cloth and with aqueous detergent suitable for the application, if needed. If there are signs of internal contamination, return the regulator unit to the supplier.
- Pressure test and leak test all systems. Purge all systems with an inert gas.

3. Installation



WARNING: Installation of the LINDE ProSpec™ Regulator involves potentially hazardous procedures. Only trained and qualified personnel who have read and who understand the information in this manual and in the supplier manuals and who have a thorough knowledge of hazardous gas systems shall install this equipment.

Follow your site's standard operating practices for installation of new equipment.

Wear appropriate PPE, and turn off the power and lock out the equipment before performing any installation, maintenance, repair, or troubleshooting procedures, per applicable requirements. For assistance, call Linde Specialty Gases & Equipment.



The customer is responsible for obtaining information on any applicable federal/national, state/provincial, and local codes or insurance requirements that affect piping and electrical installation and for obtaining all necessary approvals.



Installation of the LINDE ProSpec™ Regulator, controls, and associated piping is the responsibility of the customer unless Linde, plc. has contracted to do a turnkey installation.

The installation information in this manual is offered for use by technically qualified personnel at their discretion and risk. All statements, technical information, and recommendations are based on tests and data that Linde believes to be reliable, but the accuracy or completeness is not guaranteed, and no warranty of any kind is made with respect to this information.

Linde provides assistance in commissioning the system and may also provide technical assistance for system installation and testing to determine operating conditions.

3.1 Gas Cylinder Setup

Cap the gas cylinder and move it to the work site. After the cylinder is onsite. Complete the following steps:

1. Secure the cylinder to the floor, wall, or bench with an appropriate chain or stand to prevent toppling.
2. Remove the cylinder cap.
3. Ensure that the cylinder valve is tightly closed (clockwise).
4. Remove the cylinder valve plug, if any.
5. Inspect the cylinder valve and threads for damage or contamination.
6. Secure the regulator inlet connector to the outlet connector on the cylinder. Use an open-end wrench, not a pipe wrench.
7. The connection should easily thread. Do not force. If it is difficult, you may have the wrong regulator for the gas you are using.
8. Left hand threads are used on some inlet connectors and are indicated by a notch in the middle of the hex nut.
9. Gaskets are used on some inlet connectors and are provided with the regulator. Ensure that the gasket is in good condition. Do not over tighten to avoid squashing the gasket into the gas line. Order an extra supply of these gaskets from your gas supplier.
10. Never use oil or grease on regulator or cylinder fittings to avoid contaminating pure gases or creating a fire hazard.
11. Close the regulator by turning the pressure control knob or handle counterclockwise. As the control knob is closed, turning becomes easier.
12. Shut the regulator outlet valve (if supplied) by turning the knob on the valve clockwise.

3.2 Regulator Connection

Make connections from the regulator outlet to your downstream equipment. Complete the following steps:

1. The connection should be easily threaded. Do not force. If it is not easy, you may have the wrong regulator for the gas you are using.



WARNING: Do not use oil or grease on fittings. Especially, do not use oil or grease on oxidizing gas service equipment.

3.2 Regulator Connection

2. Ensure that all fittings are secure and leak tight. Use Teflon® tape on pipe fittings; however, avoid impinging on the gas stream. Before applying Teflon tape, inspect the National Pipe Threads (NTPs), and clean the fitting to remove any dirt or thread sealant that remains on the threads, if necessary.

Start the Teflon tape on the second thread as shown in Figure 3-1. Ensure that the tape does not overlap the end of the fitting. As the tape is wrapped in the direction of the thread spiral, pull tightly on the end of the tape so that the tape conforms to the threads.

Apply two overlapping layers of Teflon tape. Cut off the excess tape and press the end firmly into the threads.

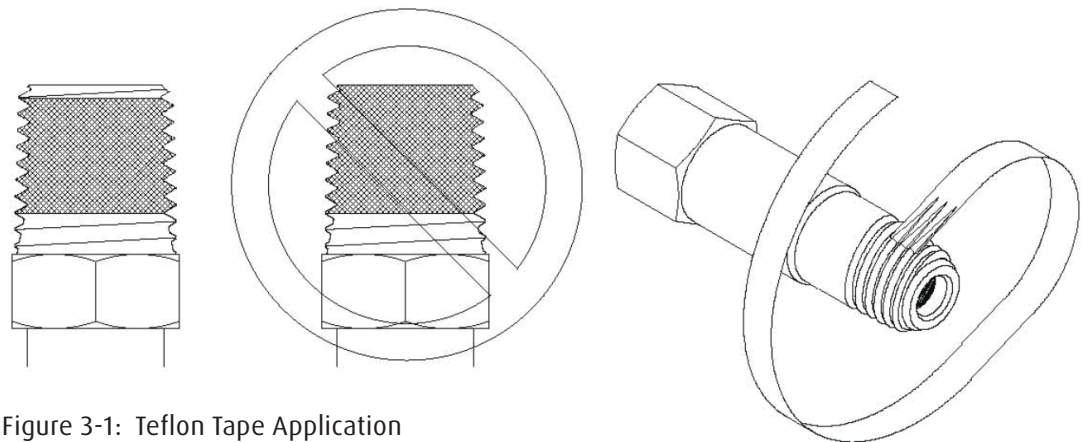

Figure 3-1: Teflon Tape Application



CAUTION: Do not apply Teflon tape to the nipple end of any CGA connection. Cylinder connections are sealed via metal-to-metal contact on a tapered surface. The CGA fittings that are flat have a sealing gasket.

3.2.1 Regulator Parts

The following parts come with some regulators:

- **Captured Vent Spring Case:** Connect the correct tubing from the vent fitting to a safe discharge area if you are using corrosive, toxic, or flammable gases.
- **Relief Valve:** Relief valves protect the regulator and its attached accessories. If there is pressure-sensitive equipment downstream of the regulator, install a relief valve in the line to protect this equipment. If you are using toxic, corrosive, or flammable gases, pipe the exhaust from the valve to a safe discharge area.
- **Purge Devices:** If your regulator includes a purge, review the safety operation in the supplier manual for your regulator.



Purge devices are highly recommended when using toxic or corrosive gases.

4. Operation



WARNING: Operation of the LINDE ProSpec™ Regulator involves potentially hazardous procedures. Only trained and qualified personnel who have read and who understand the information in this manual and in the supplier manuals and who have a thorough knowledge of hazardous gas systems shall operate this equipment. Check your site safety plan for further information on the safe operation of this equipment. Wear appropriate PPE, and turn off the power and lock out the equipment before performing any installation, maintenance, repair, or troubleshooting procedures, per applicable requirements. For assistance, call Linde Specialty Gases & Equipment.



CAUTION: Check all safety devices at least annually or as otherwise required by local codes or manufacturer recommendations. Properly maintain safety valves. Never bypass safety devices, and never operate the equipment outside its specified limits.



CAUTION: Thoroughly purge high-purity systems before use.

Take the following steps to operate the regulator:

1. Put on safety glasses and gloves.
2. Close the regulator.
 - Turn the pressure control knob or handle counterclockwise. As the control knob is closed, turning becomes easier.
 - Shut the regulator outlet valve (if supplied) by turning the knob on the valve clockwise.
3. Position yourself with the cylinder between you and the regulator. Keep your hands off the regulator while opening the cylinder valve.
4. Slowly open the cylinder valve to avoid damage to regulator parts. Check that the pressure in the high pressure gauge is rising up to full cylinder pressure.
5. Check all connections for leaks.

4. Operation (Con't)

6. Apply an approved leak detection solution to the connections, if compatible to your usage. Leaks appear as bubbles.
7. To further check for leaks or if a leak detection solution cannot be used, re-close the cylinder valve for five minutes, and check that the high-pressure gauge drops in pressure. Recheck the CGA connection and all other high-pressure port connections.
8. Fully open the cylinder valve to form a good seal at the cylinder valve packing. Keep the valve hand wheel or wrench on the open cylinder valve at all times to allow prompt emergency shutoff.
9. Turn the pressure control knob handle clockwise or to adjust to the desired working pressure, and verify on the delivery pressure gauge that the approximate desired setting is achieved.
10. Do not exceed the maximum delivery pressure indicated on the regulator label.
11. Check for leaks on the low pressure ports.
12. Check the delivery pressure gauge for any drop in pressure. If a drop is indicated, check all low pressure ports for leakage.
13. Set the delivery pressure, open the outlet valve (if any), and check your system for leaks and proper operation.
14. Adjustment to delivery pressure may be required while gas flows through your system.
 - **Two-Stage Regulators:** After the final setting of delivery pressure, do not make any further adjustments as the cylinder depletes.
 - **Single-Stage Regulators:** After final setting of delivery pressure, periodically adjust delivery pressure as the cylinder depletes, if necessary.



As a general rule, a cylinder is considered "empty" when the cylinder pressure drops to a value of two times the delivery pressure or less. This avoids the possibility of dangerous suck-back conditions. However, particular system requirements may indicate greater or less margin. Contact your Linde representative for any questions.

4.1 Temporary Shutdown

A temporary shutdown is a shutdown that is less than 30 minutes. Close the regulator outlet valve (if supplied). If the regulator does not have an outlet valve, follow the procedure in section 4.2.

4.2 Extended Shutdown

An extended shutdown is a shutdown that is greater than 30 minutes.

4.2.1 Normally Open Systems or Complete System Disassembly

This information applies when there is no concern about entry of atmospheric gases into the system.

Take the following steps to perform an extended shutdown:

1. Close the gas cylinder valve.
2. Shut down any other gas supplies that may be connected to your system.
3. Turn the adjusting knob clockwise, and then open the outlet valve to drain the line through your usage points. Both regulator gauges descend to zero.
4. For hazardous gases, run an inert purging gas through the regulator and system before disassembly.
5. After venting (and purging when applicable), turn the adjusting knob fully counterclockwise and close the outlet valve.
6. Disconnect the downstream equipment.
7. When disassembling, slowly loosen the cylinder valve connection while listening for gas seepage. If a leak is evident, re-tighten the connection and check that the cylinder valve closes.
8. Cap the cylinder after disconnecting the regulator. Mark the cylinder "EMPTY" if this is true, and move it to the storage area for returned cylinders.
9. If hazardous gases were used and a system purge was not performed, direct a stream of dry nitrogen through the fully opened regulator. When using hazardous gases or when in a confined area, provide a safe discharge area when clearing the regulator.
10. Install a new cylinder, if necessary.
11. When a regulator is out of service, close the pressure control knob by turning it counterclockwise until the spring tension relieves, and then close the outlet valve. Cap the open ends of the regulator, or if removed, store it in a plastic bag to prevent contamination (unobserved particulate buildup inside the regulator).

4.2.2 Isolated Gas Systems

Some practices (especially on High-Purity Systems) demand that ambient air be excluded from the system. Take the following steps to exclude ambient air:

1. Seal the usage gas in the system.



CAUTION: Do not use 'seal the usage gas' method with hazardous gases for long periods.

2. Exert a vacuum on the system after shutdown.
3. Replace the system gas with an inert gas.

4.3 Isolated System Cylinder Change



CAUTION: Do not use a unit that is malfunctioning until all required repairs are complete and the unit is tested to confirm proper operation.

A valve upstream of the regulator is required for the isolated gas system cylinder change and is provided when an upstream purge device (for example, Linde Deep Purge) is used.

Take the following steps to perform an isolated system cylinder change:

1. Tightly close the gas cylinder valve.
2. Close the valve upstream of the regulator (the center or master valve on the Deep Purge).
3. For hazardous gases, purge the cylinder valve cavity using procedures contained in the supplier manual for your purge assembly.
4. When disassembling, slowly loosen the cylinder valve connection while listening for gas seepage. If a leak is evident, re-tighten the connection and check that the cylinder valve closes.
5. Cap the cylinder after disconnecting the regulator. Mark the cylinder "EMPTY" if this is true, and move it to the storage area for returned cylinders.
6. If hazardous gases were used and a system purge was not performed, direct a stream of dry nitrogen through the fully opened regulator. When using hazardous gases or when in a confined area, provide a safe discharge area when clearing the regulator.
7. Seal the system to maintain a vacuum after shutdown because leaks can pull impurities into the system.
8. Maintain positive pressure when filling the system with an inert gas to reduce the probability of impurities entering the system.

5. Maintenance and Repair



WARNING: Maintenance and repair of the LINDE ProSpec™ Regulator involves potentially hazardous procedures. Only trained and qualified personnel who have read and who understand the information in this manual and in the supplier manuals and who have a thorough knowledge of hazardous gas systems shall work on this equipment. Wear appropriate PPE, and turn off the power and lock out the equipment before performing any installation, maintenance, repair, or troubleshooting procedures, per applicable requirements. For assistance, call Linde Specialty Gases & Equipment.



WARNING: Ensure that no residual pressure is in the piping by isolating the gas supplies and then relieving any piping pressure. Follow appropriate lockout/tagout procedures before beginning maintenance, repair, or troubleshooting procedures.



CAUTION: Check all safety devices at least annually or as otherwise required by local codes or manufacturer recommendations. Properly maintain safety valves. Never bypass safety devices, and never operate the equipment outside its specified limits.



CAUTION: Do not use a regulator that is not properly functioning until repairs are performed and the unit is tested to ensure quality and safety.



“ProSpec™” is the new brand-name for the “ProStar® Platinum” series of products from LINDE Specialty Gases & Equipment. ProSpec regulators are designed for high-pressure gas cylinder applications.



For additional details, ordering information, operation, and safety guidelines, go to www.LindeDirect.com or call 1-877-772-9247.

Test the regulator for leaks on a routine schedule. All servicing is to be performed by a service facility authorized by Linde. Call Linde Customer Service for equipment problems.

Provide the model number and serial number of the equipment involved, and details regarding its application. Contact your local Linde Customer Service Department or the nearest Linde District Sales Office for assistance.

- Purge all equipment to protect the transporter and service personnel. Purge is especially important when equipment was in a hazardous or corrosive gas service.
- Place the unit in adequate packaging (the original shipping container, if possible) and ship prepaid with a statement of observed deficiency to a service facility authorized by Linde.
- Identify the gas service for which the equipment was used. Return trip transportation charges are to be paid by the Buyer.
- In all cases outside of warranty, repairs are made at the current list price for the replacement part(s) plus labor.

6. Trouble Shooting



CAUTION: This troubleshooting guide contains general information only. Refer to the specific sections of this manual and the supplier manuals that address the issues in more detail before proceeding.

This equipment is designed to operate properly and efficiently. However, as with any equipment, malfunctions can occur. Use the information in this chapter to troubleshoot any operating abnormalities.

The information presented may not cover every specific situation. Consult your Linde representative for assistance.

This troubleshooting guide is provided to help you identify and correct any faults that may occur during startup and operation of the equipment. A good understanding of the system and its operation is important for safe and efficient troubleshooting.

Only qualified personnel who understand the process and who have read this manual shall troubleshoot the system. Report any problems with the system to your Linde representative.



“ProSpec™” is the new brand-name for the “ProStar® Platinum” series of products from Linde® Specialty Gases & Equipment. ProSpec regulators are designed for high-pressure gas cylinder applications.



For additional details, ordering information, operation, and safety guidelines, go to www.LindeDirect.com or call 1-877-772-9247.

Table 6-1
Troubleshooting

Problem	Probable Cause	Action
Gas leakage at the regulator outlet when the adjusting screw is fully turned counterclockwise.	Seat leak or creep.	Send the regulator for repair.
No flow through the system (downstream valves are closed); therefore, outlet pressure steadily increases above the set pressure.	Seat leak or creep.	Send the regulator for repair.
Gas leakage from spring case or bonnet.	Diaphragm failed.	Send the regulator for repair.
Excess drop in outlet pressure with the regulator flow open.	Blockage in seat assembly or inlet filter.	Send the regulator for repair.
Gas leakage from any pipe thread joint.	Fitting is loose.	Remove the connection, clean, reapply Teflon tape, and retighten.
Gas leakage from the relief valve.	Possible faulty relief valve.	Replace the relief valve.
	Possible seat leak or creep.	Send regulator for repair.
Inconsistent repeat readings.	Seat is sticking.	Send regulator for repair.
	Possible bad pressure gauge.	Send regulator for repair.
When pressure is not applied to the regulator, inlet or outlet pressure gauge does not return to zero.	Gauge has physical damage.	Replace the gauge.

Index

A		M	
Asphyxiation 1-5		Maintenance and Repair4-1	
B		N	
Basic Hazards 1-5		Normally Open Systems or Complete System Disassembly 4-3	
Asphyxiation 1-3		Notices iii	
Electrocution 1-4		O	
Pressure 1-4		Operation 4-1	
Gas Processing Equipment and Fires 1-5		Oxidizers 1-8	
Oxidizers 1-5		P	
Confined Space 1-5		Poisons 1-8	
Basic Safety Recommendations 1-4		Pressure 1-6	
C		R	
Cleaning 1-9		Reactivity 1-9	
Cleaning for Oxygen Service 1-9		Read These Instructions v	
Cleaning Precautions 1-10		References 1-10	
Corrosion 1-8		Regulator Connection 3-2	
E		Regulator Parts 3-3	
Equipment Description 2-1		S	
Extended Shutdown 4-3		Safety	
F		Shutdown 3-7	
Flammability 1-7		T	
G		Temporary Shutdown 4-3	
Gas Cylinder Setup 3-2		Toxicity 1-7	
Gas Processing Equipment and Fires 1-6		Troubleshooting 6-1	
I		U	
Installation3-1		User Responsibility 1-3	
Isolated Gas Systems 4-4			
Isolated System Cylinder Change 4-4			
